

THIS DRAWING IS UNPUBLISHED. RELEASED FOR PUBLICATION
 © COPYRIGHT - By - TE CONNECTIVITY ALL RIGHTS RESERVED.

LOC	DIST	REVISIONS				
P	LTR	DESCRIPTION	DATE	DWN	APVD	
HB	-	D	OPTIMIZATION SSA RATING&USING WELDED CONTACT ECO-13-017354	12Feb2014	HYS	F.B

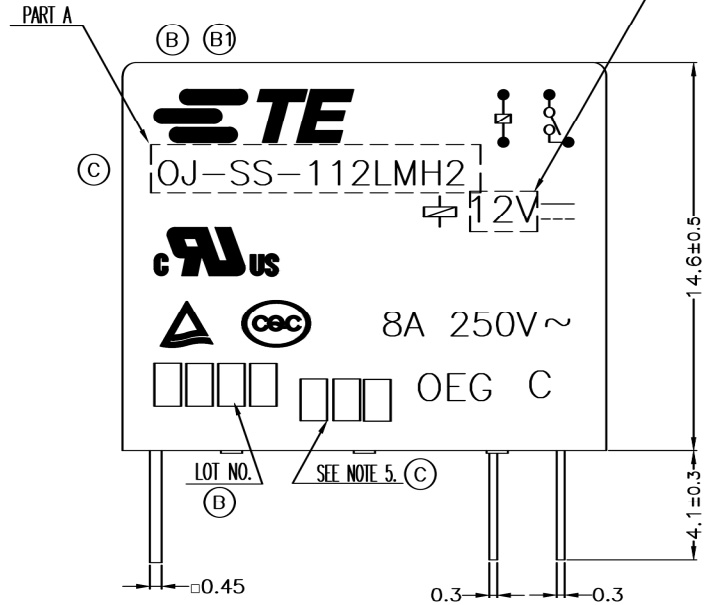
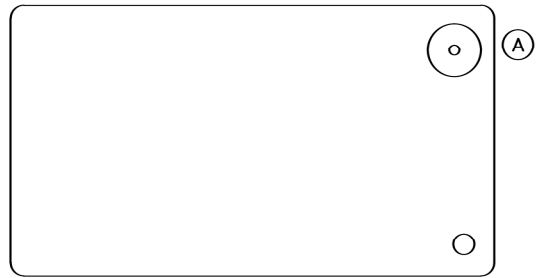

PART B

PART A

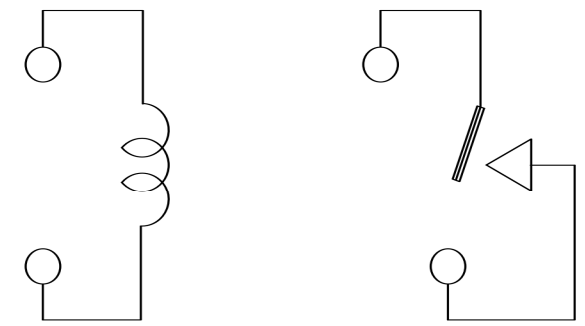

CONNECTION FIGURE

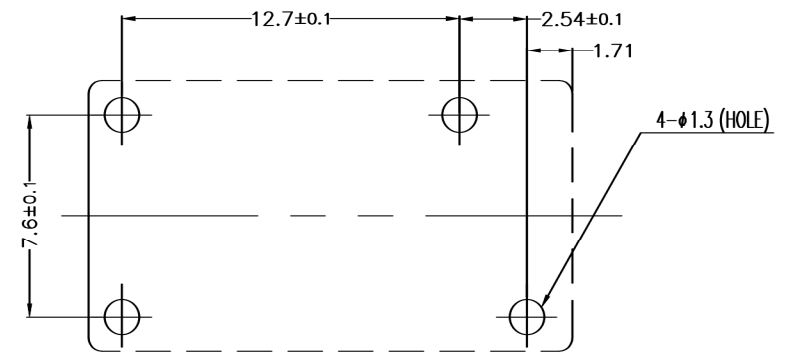
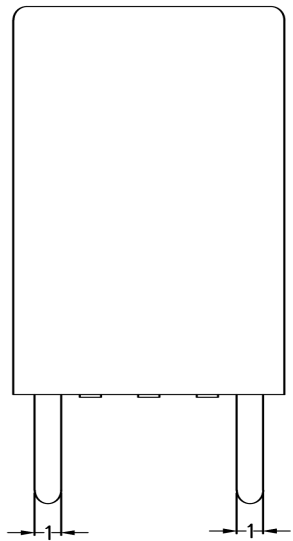

FIGURE FOR PRINTED CIRCUIT BOARD PROCESSING (BOTTOM VIEW)

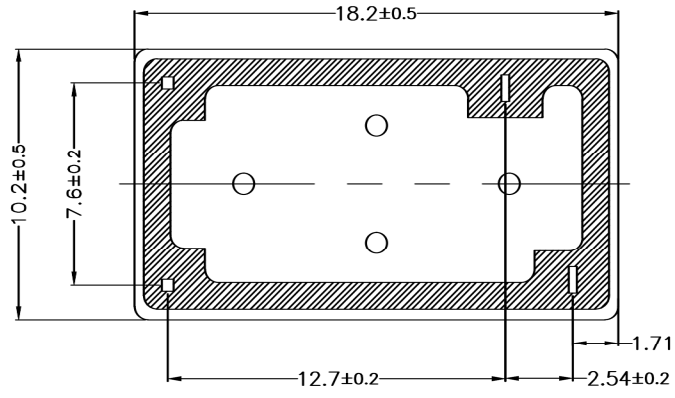

Diagram dimension	Tolerance
0.99mm max.	±0.1mm
1 - 2.99mm	±0.2mm
3mm min.	±0.3mm

THIS DRAWING IS A CONTROLLED DOCUMENT.		DWN	Hu.Xieli	-	 TE Connectivity	
DIMENSIONS: mm		CHK	Mingjung, Ho	-		
TOLERANCES UNLESS OTHERWISE SPECIFIED:		APVD	Mak, simon	-		
0 PLC ± - 1 PLC ± - 2 PLC ± - 3 PLC ± - 4 PLC ± - ANGLES ± - FINISH ± -		NAME	-			
MATERIAL		PRODUCT SPEC	SEE PRODUCT SPEC		SIZE	A3
		APPLICATION SPEC	-		CAGE CODE	00779
		WEIGHT	-		DRAWING NO	1721260
		CUSTOMER DRAWING		SCALE	5:1	SHEET 1 OF 2
				RESTRICTED TO	-	
				REV	D	

THIS DRAWING IS UNPUBLISHED. RELEASED FOR PUBLICATION
 © COPYRIGHT - By - TE CONNECTIVITY ALL RIGHTS RESERVED.

LOC	DIST	REVISIONS					
HB	-	P	LTR	DESCRIPTION	DATE	DWN	APVD
		-		SEE SHEET 1	-	-	-

PACKAGE SPEC	TE PART NO	DESCRIPTION	PART B	PART A	TYPE
107-79010	1-1721260-2	OJ-SH-124LMH2	24V	OJ-SH-124LMH2	l (C) (O)
	1-1721260-1	OJ-SH-112LMH2	12V	OJ-SH-112LMH2	k (O)
	1-1721260-0	OJ-SH-109LMH2	9V	OJ-SH-109LMH2	j (C) (O)
	1721260-9	OJ-SH-106LMH2	6V	OJ-SH-106LMH2	i (C) (O)
	1721260-8	OJ-SH-105LMH2	5V	OJ-SH-105LMH2	h (O)
	1721260-7	OJ-SH-103LMH2	3V	OJ-SH-103LMH2	g (C) (O)
	1721260-6	OJ-SS-124LMH2	24V	OJ-SS-124LMH2	f
	1721260-5	OJ-SS-112LMH2	12V	OJ-SS-112LMH2	e
	1721260-4	OJ-SS-109LMH2	9V	OJ-SS-109LMH2	d (C)
	1721260-3	OJ-SS-106LMH2	6V	OJ-SS-106LMH2	c
	1721260-2	OJ-SS-105LMH2	5V	OJ-SS-105LMH2	b (C)
	1721260-1	OJ-SS-103LMH2	3V	OJ-SS-103LMH2	a

RELAY TYPE

(B) NOTES:

1. LOT NO. SYSTEM AS FOLLOWING: (C) 5. ADD LOT NO. SYSTEM AS FOLLOWING;

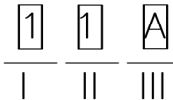
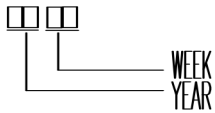

I, DIGITS FOR DAY OF THE WEEK
 1...MONDAY IN THIS WEEK;
 2...TUESDAY IN THIS WEEK;

 7...SUNDAY IN THIS WEEK

II, DIGITS FOR SHIFT OF THE DAY
 1...DAY SHIFT IN THIS DAY;
 2...NIGHT SHIFT IN THIS DAY;

III, ONE CHARACTER DISTINGUISH THE LINE IDENTITY,
 SUCH AS: A,B,....Z

(C) 2. TERMINAL DIMENSION IS BEFORE SOLDER DIP;

(C) 3. FOR THE TIN-PLATING OF THE PINS:
 +0.1mm FOR WIDTH, THICKNESS AND DIAMETER.
 +0.5mm FOR LENGTH.

(D) (C) 4. MARKING FROM INK TO LASER AND USING WELDED CONTACT

INCOMBUSTIBILITY	TREATMENT	MATERIAL	DESCRIPTION	ITEM
		UV RESIN	UV SEAL	16
		EPOXY RESIN	SEAL (BASE & BOBBIN)	15
		SUEW	MAGNETIC WIRE	14
UL94V-0		P.B.T	CASE	13
UL94V-0		P.B.T	BASE	12
UL94V-0		P.B.T	BOBBIN	11
	SOLDER DIP	C.P. WIRE	COIL TERMINAL	10
UL94V-0		P.P.S	CARD	9
		AgSnOInO	MOVABLE CONTACT	8
		AgSnOInO	NO CONTACT	7
		STEEL	HINGE SPRING	6
	SOLDER DIP	Cu ALLOY	NO TERMINAL	5
	SOLDER DIP	Cu ALLOY	MOVABLE SPRING	4
	NIP	STEEL	CORE	3
	NIP	STEEL	ARMATURE	2
	NIP	STEEL	YOKE	1

THIS DRAWING IS A CONTROLLED DOCUMENT.		DWN	Hu.Xieli	-
DIMENSIONS: mm		CHK	Mingjung, Ho	-
TOLERANCES UNLESS OTHERWISE SPECIFIED:		APVD	Mak, simon	-
	0 PLC	± -	NAME	
	1 PLC	± -	OJ-KMH2 SPEC.000 CUSTOMER DRAWING	
	2 PLC	± -	SIZE	A3
	3 PLC	± -	CAGE CODE	00779
4 PLC	± -	DRAWING NO	1721260	RESTRICTED TO
ANGLES	± -	WEIGHT	-	-
MATERIAL	FINISH	CUSTOMER DRAWING		
		SCALE	5:1	SHEET 2 OF 2
		REV	D	